

EM Sensor System for Characterisation of Advanced High Strength Steels

Mohsen Jolfaei

Academic Supervisors : Prof Claire Davis, Dr Lei Zhou
Industrial supervisor : Dr Andy Smith

Annual Symposium 2018
27th February 2018



Introduction

- The increasing requirements of passenger safety, vehicle performance and fuel efficiency in the automotive industry means that improved steel grades are required.
- There has been growing attention to the manufacturing of dual phase(DP) steels for their high strength allowing light-weighting of automotive components.
- DP steels are characterised by a combination of continuous yielding behaviour, good formability and high tensile strength.



Introduction

- The increasing requirements of passenger safety, vehicle performance and fuel efficiency in the automotive industry means that improved steel grades are required.
- There has been growing attention to the manufacturing of dual phase (DP) steels for their high strength allowing light-weighting of automotive components.
- DP steels are characterised by a combination of continuous yielding behaviour, good formability and high tensile strength.

COLOR	MPa	
Red	1180	COMPLEX PHASE (MARTENSITE+FERRITE+BAINITE+RETAINED AUSTENITE)
Orange	980	DUAL PHASE (MARTENSITE+FERRITE)
Yellow	780	DUAL PHASE (MARTENSITE+FERRITE)
Green	590	DUAL PHASE (MARTENSITE+FERRITE)
Cyan	440	QUASI HIGH STRENGTH
Purple	390	QUASI HIGH STRENGTH
Grey	MILD	SHOWN IN GREY (IN PICTURE) SHOWN IN WHITE (ON DISPLAY VEHICLE)

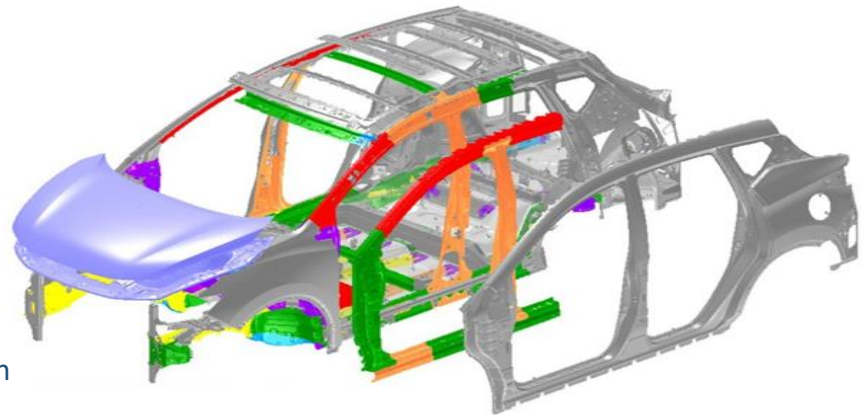

Different grade of DP steel in automotive application
[repairerdrivennews.com]

Introduction

- For product development it is very important to have reliable quantitative phase fraction data to be able to fully comprehend the influence of chemistry and process conditions on the final microstructure.
- The conventional methods e.g. optical microscopy and (SEM) to obtain phase information are destructive, and time consuming.
- The EM sensor measurements are non-destructive, have a fast response, can operate in a non-contact manner, are unaffected by dust, water and are relatively inexpensive.

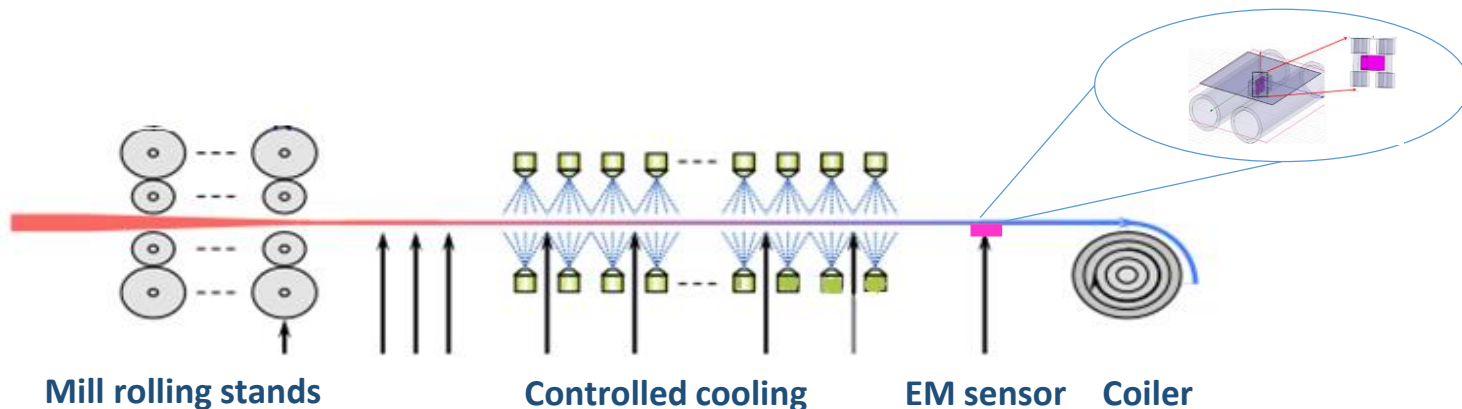

Aim of Research

- Relationship between the magnetic properties, microstructure and mechanical properties (hardness and strength)
- Off-line electro-magnetic sensor to characterise (i.e. quantitative) phase fraction and prediction of strength for advanced high strength steels

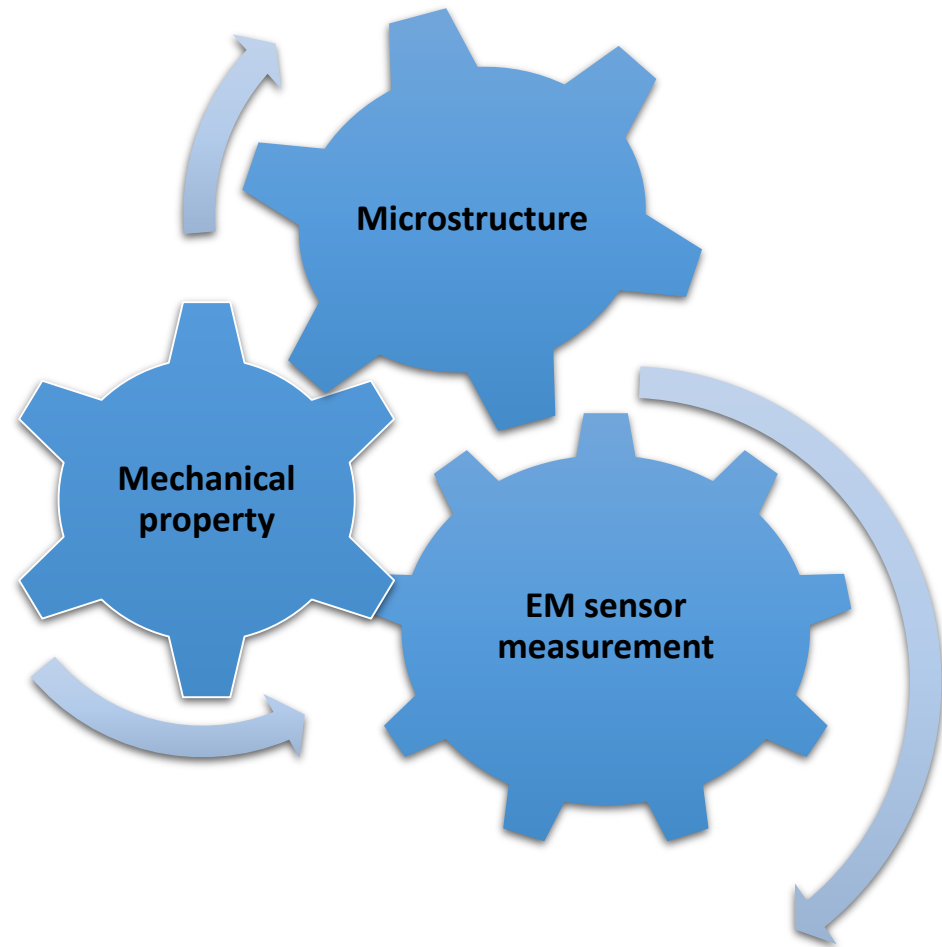

Background

- The mechanical properties of DP steel are strongly influenced by its microstructural parameters, in particular phase balance (ferrite & martensite) and grain size.
- Multi-frequency electromagnetic (EM) sensors are sensitive to both changes in relative permeability and resistivity of steel, with the low frequency inductance values being directly related to the permeability.
- The permeability is affected by microstructural features (i.e. phase fraction / distribution and, to a lesser extent, grain size).

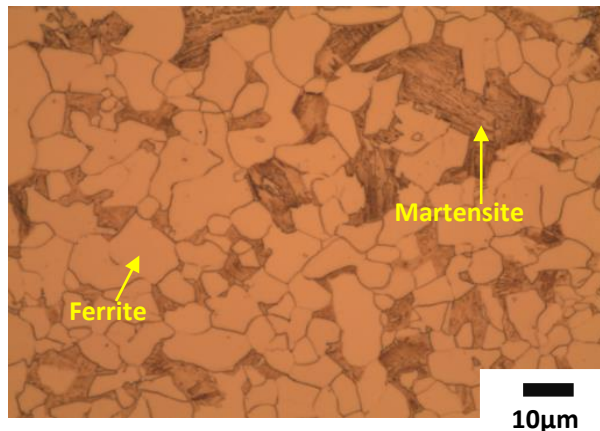

Optical microstructure of DP600



Different type of EM sensors

Microstructure

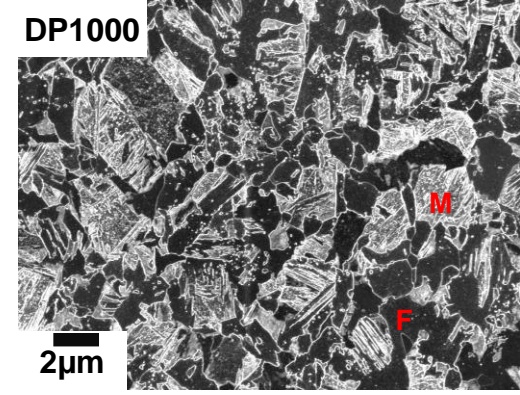
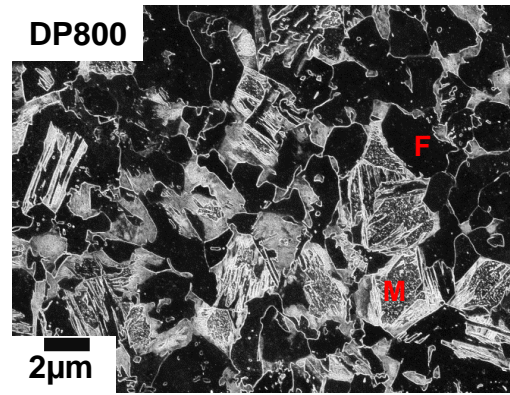
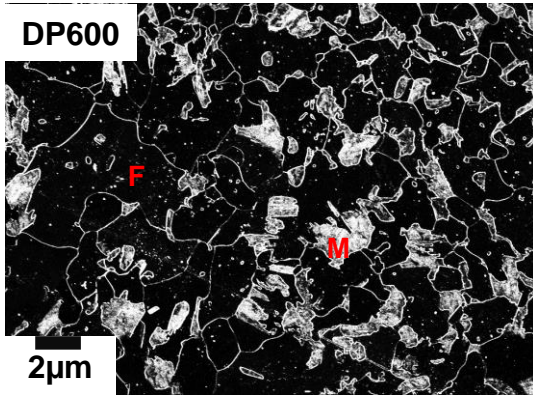

- Dual phase (DP) steels have a microstructure consisting of a continuous soft ferrite matrix (high relative permeability) and hard dispersed second phase (martensite with low relative permeability) particles throughout the matrix.
- Different volume fraction of ferrite-martensite gives different DP steel.

Laboratory Magnetic Permeability Measurement

BH Hysteresis loops

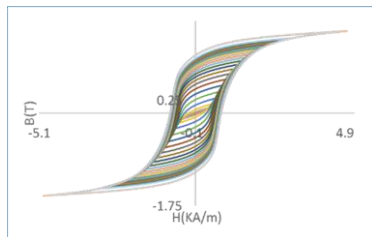
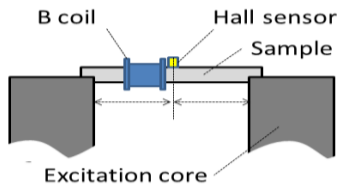
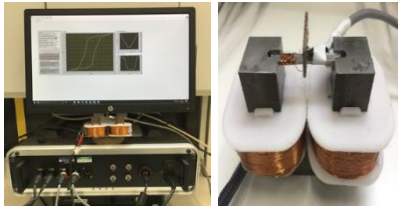

Laboratory Magnetic Permeability Measurement

BH Hysteresis loops

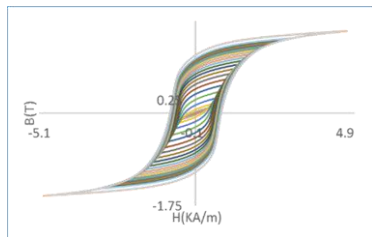
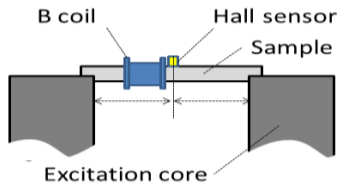
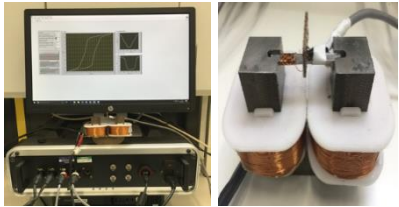

Magnetic property - Microstructural Model

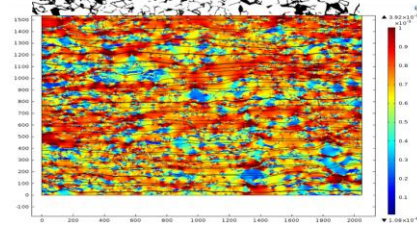
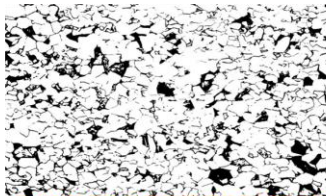
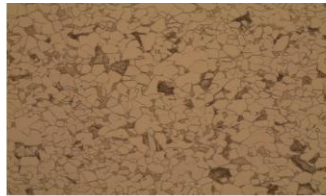

Laboratory Magnetic Permeability Measurement

BH Hysteresis loops

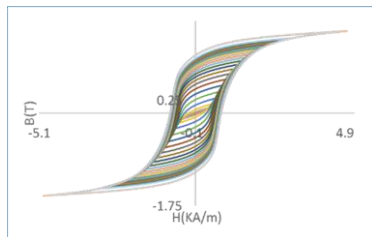
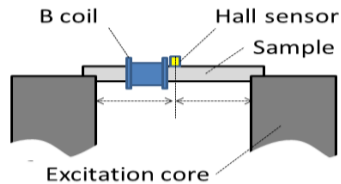
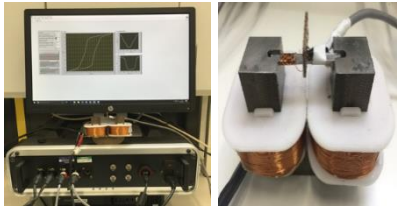

Magnetic property - Microstructural Model

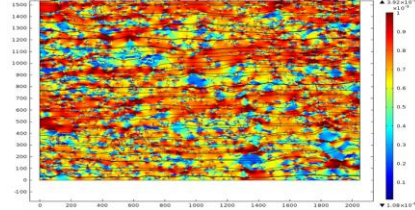
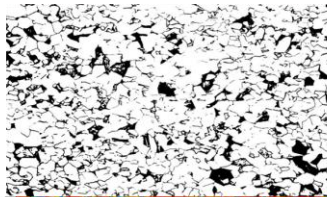
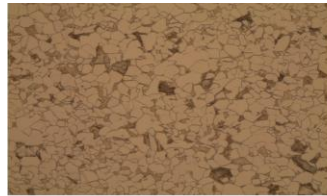

FE Modelling Cylindrical Sensor

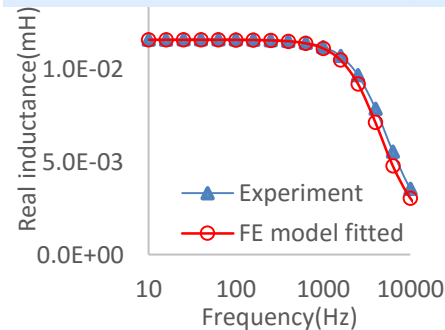
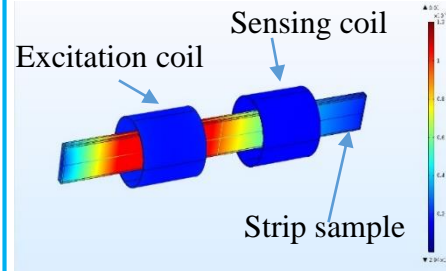

Laboratory Magnetic Permeability Measurement

BH Hysteresis loops

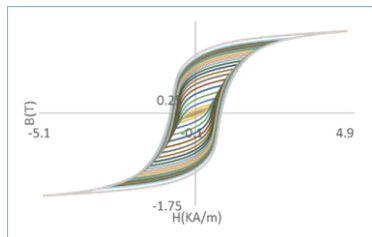
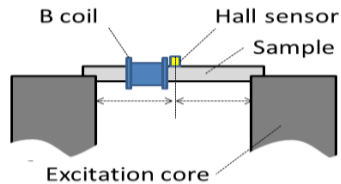
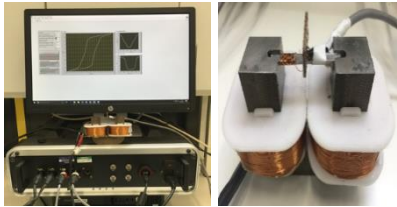

Magnetic property - Microstructural Model

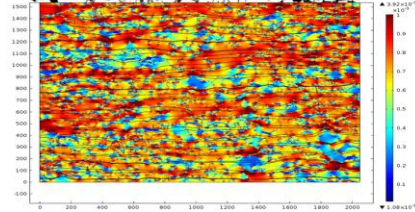
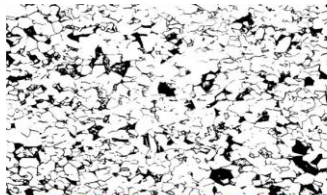
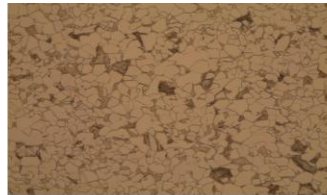

FE Modelling Cylindrical Sensor

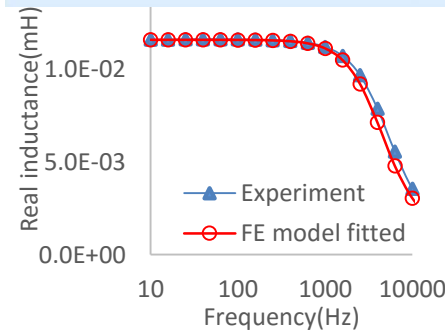
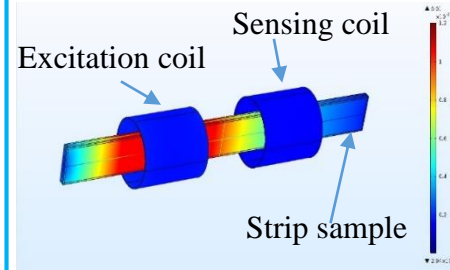

FE Modelling U-Shaped Sensor

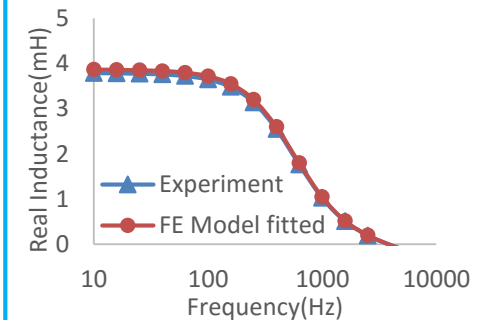
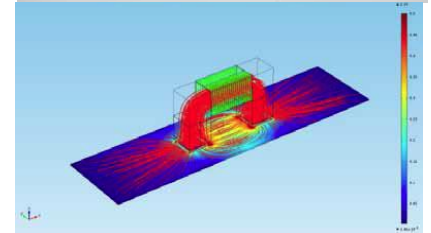
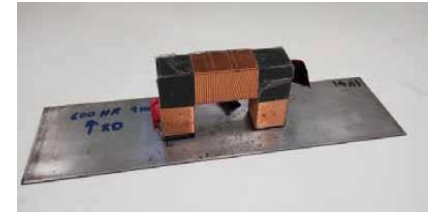

Permeability Vs Tensile strength

- Permeability has been determined from FE U-shaped sensor modelling . The values are similar to the relative permeability values as well as other permeability measured by alternative measurements
- There is a good correlation between tensile strength and permeability.

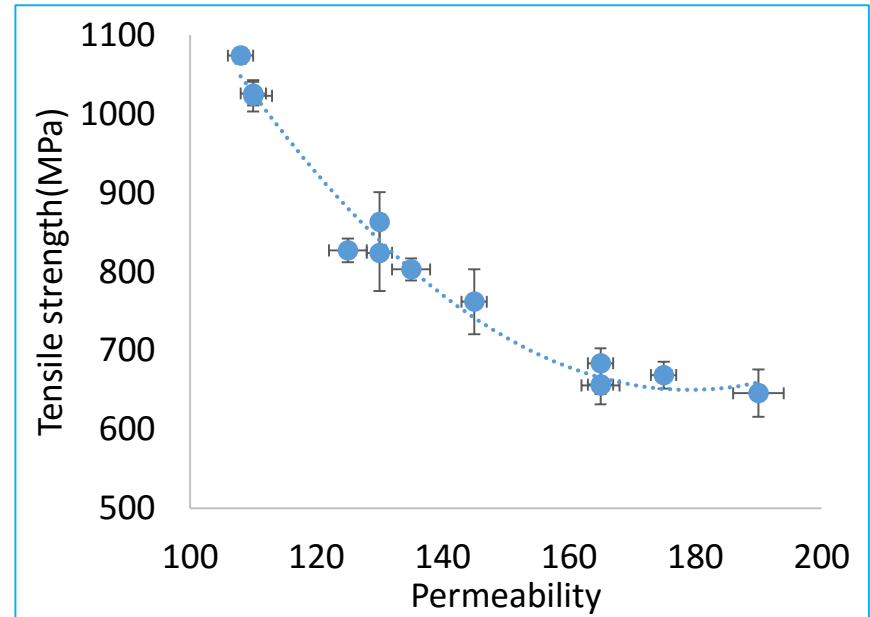

Microstructure - Mechanical property

- To determine the relationship between the phase fraction and strength, the ferrite fraction and tensile strength were quantified.
- The decrease in tensile strength with increasing volume fraction of ferrite for the DP steel is well known and widely documented.
- There is a clear decrease in the tensile strength with an increase in ferrite fraction for DP grades, which is related to the lower martensite (or bainite) fraction.
- A lot more scatter is seen for the DP800 grades.

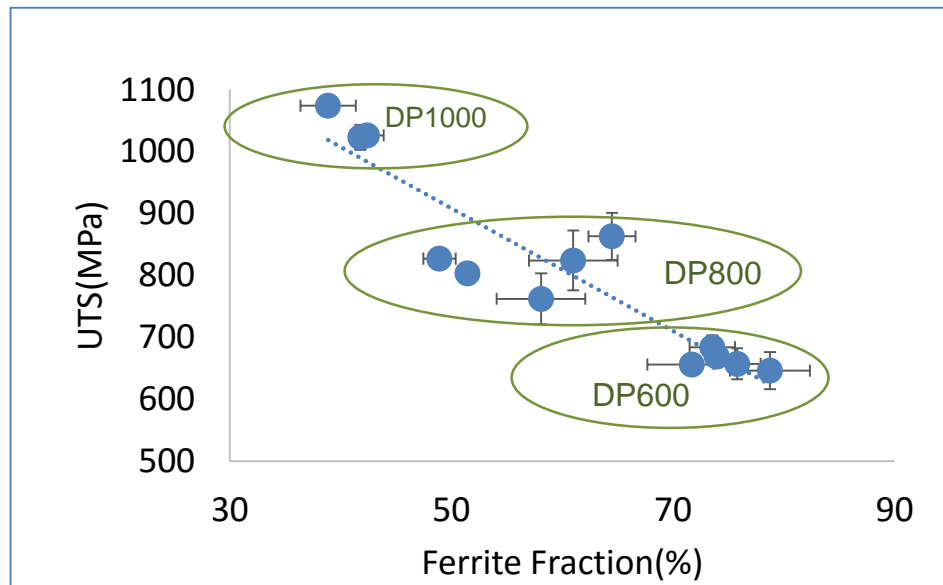

Microstructure - Mechanical property

- To determine the relationship between the phase fraction and strength, the ferrite fraction and tensile strength were quantified.
- The decrease in tensile strength with increasing volume fraction of ferrite for the DP steel is well known and widely documented.
- There is a clear decrease in the tensile strength with an increase in ferrite fraction for DP grades, which is related to the lower martensite (or bainite) fraction.
- A lot more scatter is seen for the DP800 grades.

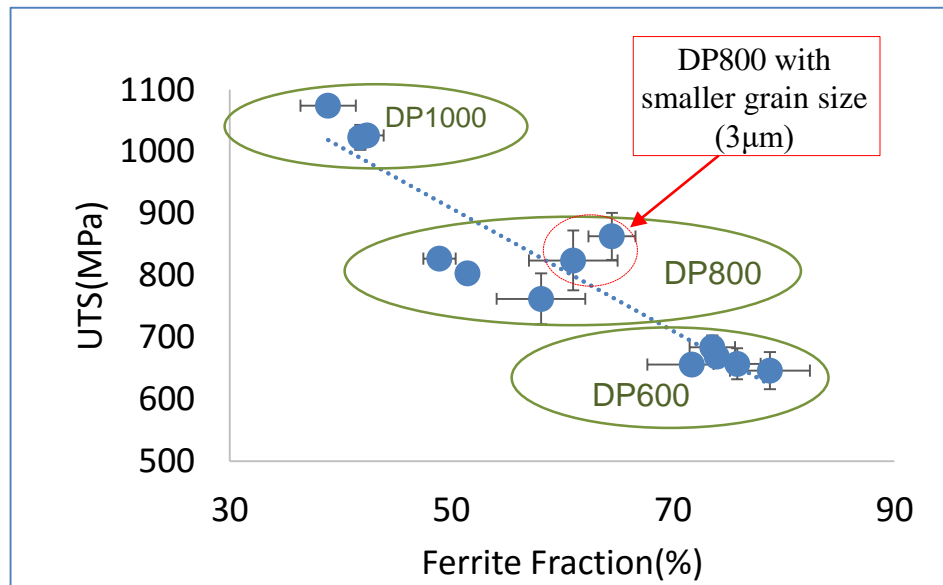

Ferrite fraction - Permeability Vs Tensile strength

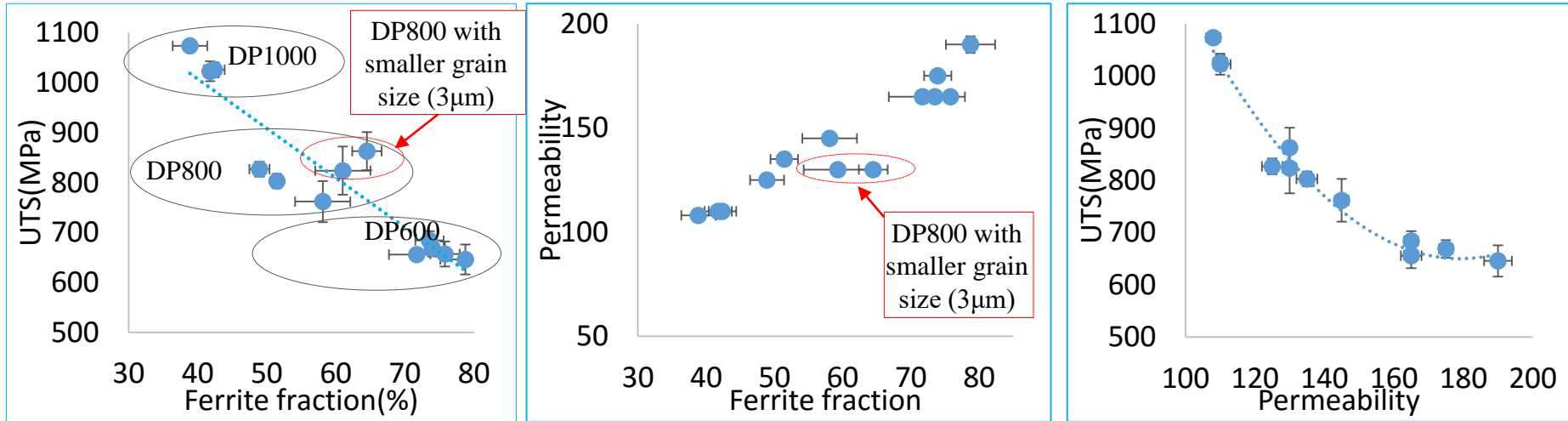

- The relationship between the phase fraction and strength shows scatter as grain size is not included and the grain size varied in the DP steels investigated.
- There is more scatter for the DP800 grades.
- It is known that the grain size can affect the permeability
- Clear relationship is seen between UTS and permeability as both are affected by phase fraction and grain size.

EM Sensor Measurement

- For industrial use there needs to be a sensor that can measure sheet product and the U-shaped one is the best option.
- A U-shaped multi-frequency EM sensor was used on sheet samples (the size of sample is 300 x 80mm).
- The sensor consists of one generating coil with 100 turns and two sensing coils with 86 turns with a bridge of 100mm, leg lengths and thickness of 56mm and 25mm respectively.
- Impedance analyser Solartron 1260 with an AC voltage of 3V at a frequency of 1-100KHz.

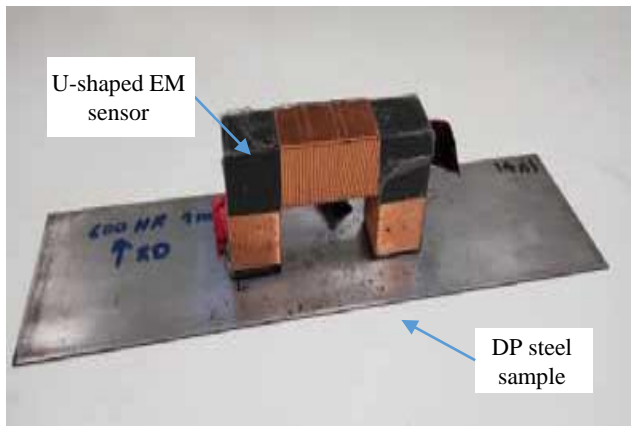

U-shaped sensor is driven using Impedance analyser Solartron 1260

EM Sensor Measurement

- The real inductance versus frequency plot for the U-shaped EM sensor shows a plateau in inductance value at low frequency (10-100Hz) in the region where the signal is independent of the electrical resistivity but dependent on the relative permeability of the sample.
- Low frequency inductance increases almost linearly with ferrite fraction in the range of 35-73% for the uniform thickness (1.4mm) heat treated DP600 steels, which all have a similar grain size.

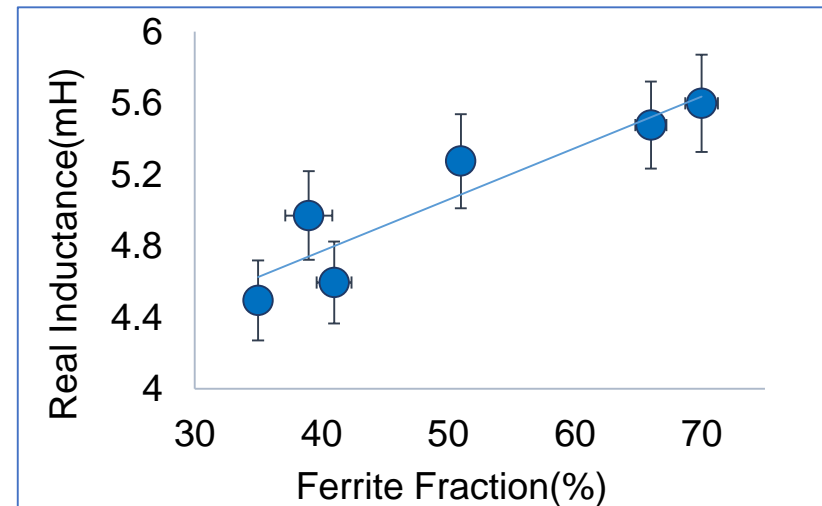
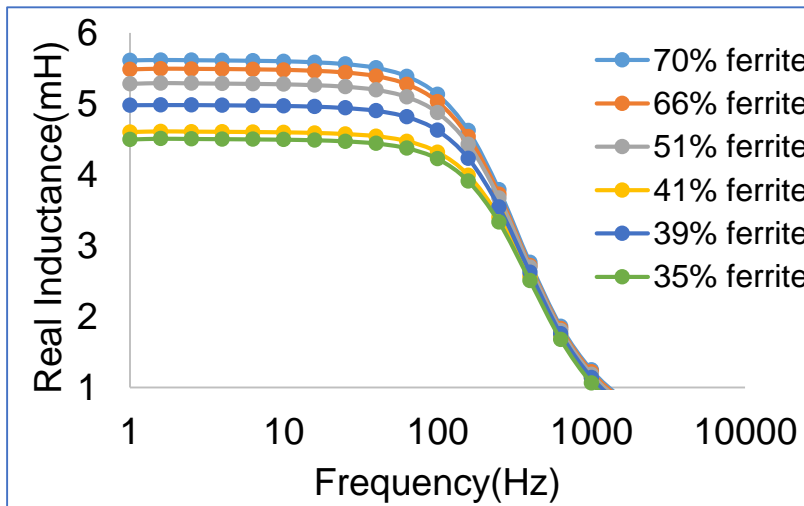

Effect of Thickness

- For the commercial DP steel grades with different thicknesses (and similar ferrite fraction) the inductance is strongly affected by the thickness of the sample.
- Thicker sample shows a higher mutual inductance sensor response as effectively more material is being measured
- The thickness of material affecting the sensor signal can be estimated by the skin depth equation;

$$\Delta s = \sqrt{\frac{\rho}{\pi f \mu_0 \mu_r}}$$

Where ρ is the resistivity, f is frequency, μ is absolute magnetic permeability ($\mu = \mu_0 \cdot \mu_r$).

- The sensor signal cannot be directly correlated to tensile strength of different strip thickness unless a calibration curve is generated to account for the thickness effect.

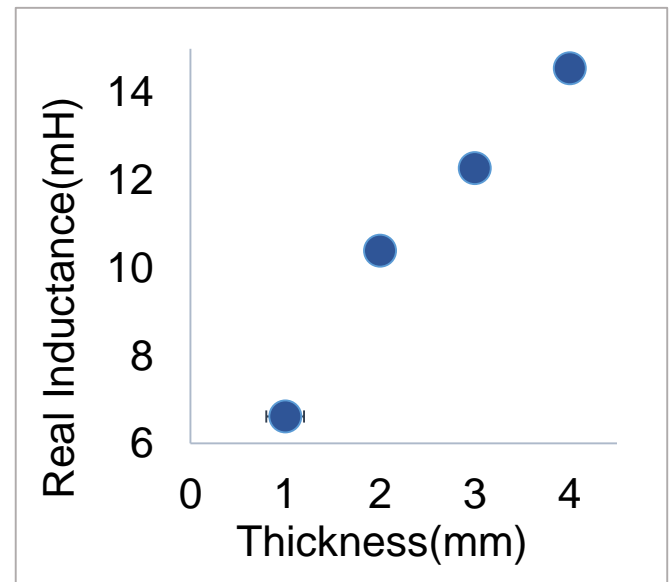

The real inductance measurements of commercial DP600 samples (with 79% ferrite, average grain size $10 \pm 4 \mu\text{m}$) steels with thickness of 1mm - 4mm

Calibration Curve

- A calibration curve has been generated to account for the effect of thickness on the EM signal
- A combination of 3D FE modelling with experimental data for initial fitting of the model then validation.
- By measuring the sensor signal (i.e. real inductance measurement) the permeability of any thickness steel sheet is determined

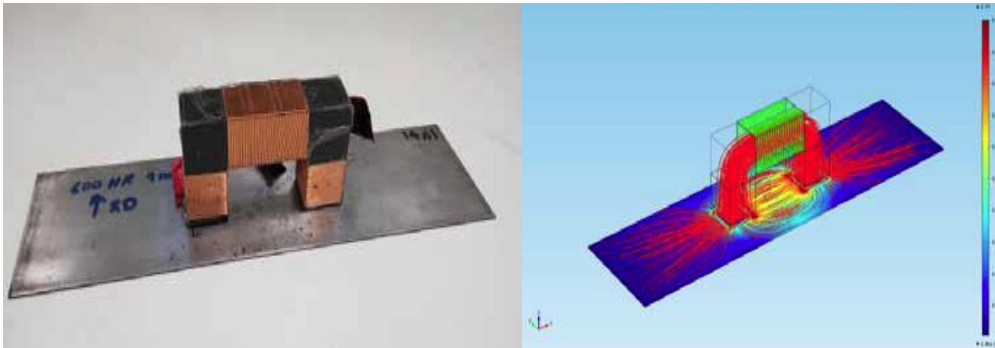

U-shapes EM sensor and view of the 3D FE modelling

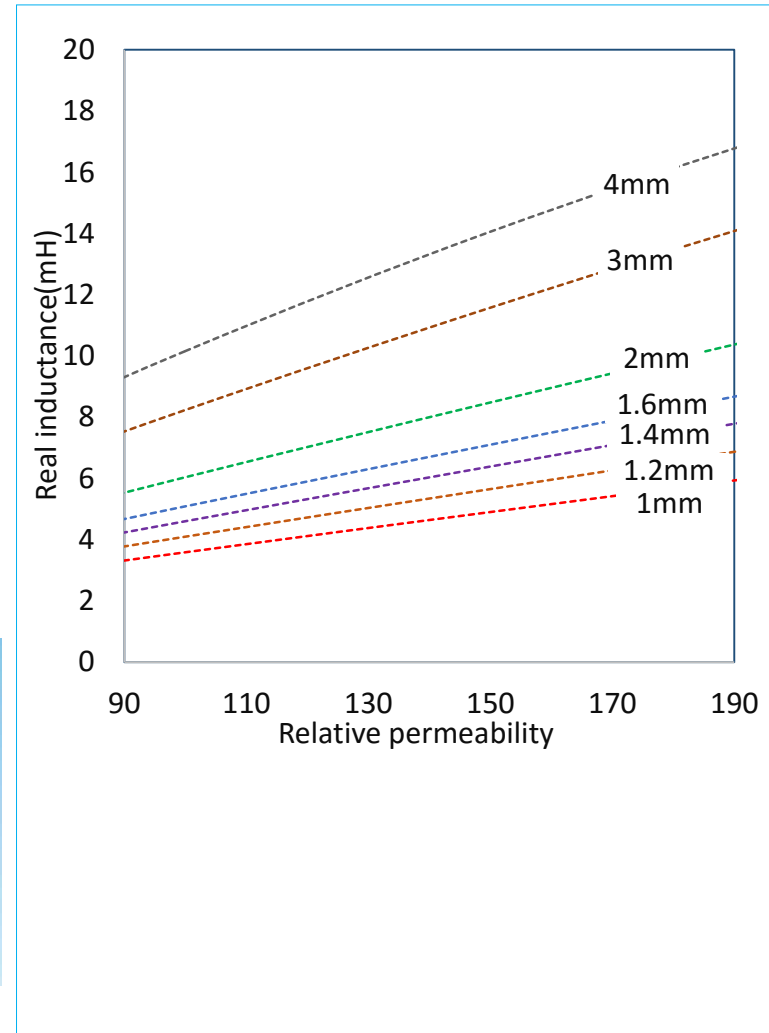

Calibration Curve

- A calibration curve has been generated to account for the effect of thickness on the EM signal
- A combination of 3D FE modelling with experimental data for initial fitting of the model then validation.
- By measuring the sensor signal (i.e. real inductance measurement) the permeability of any thickness steel sheet is determined

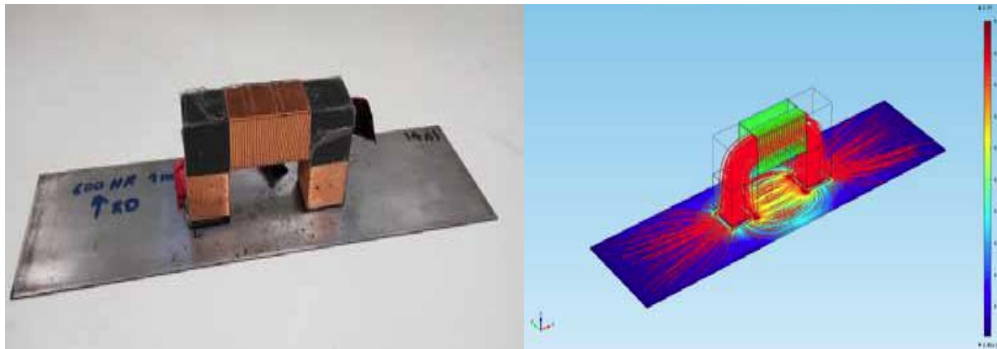

U-shapes EM sensor and view of the 3D FE modelling

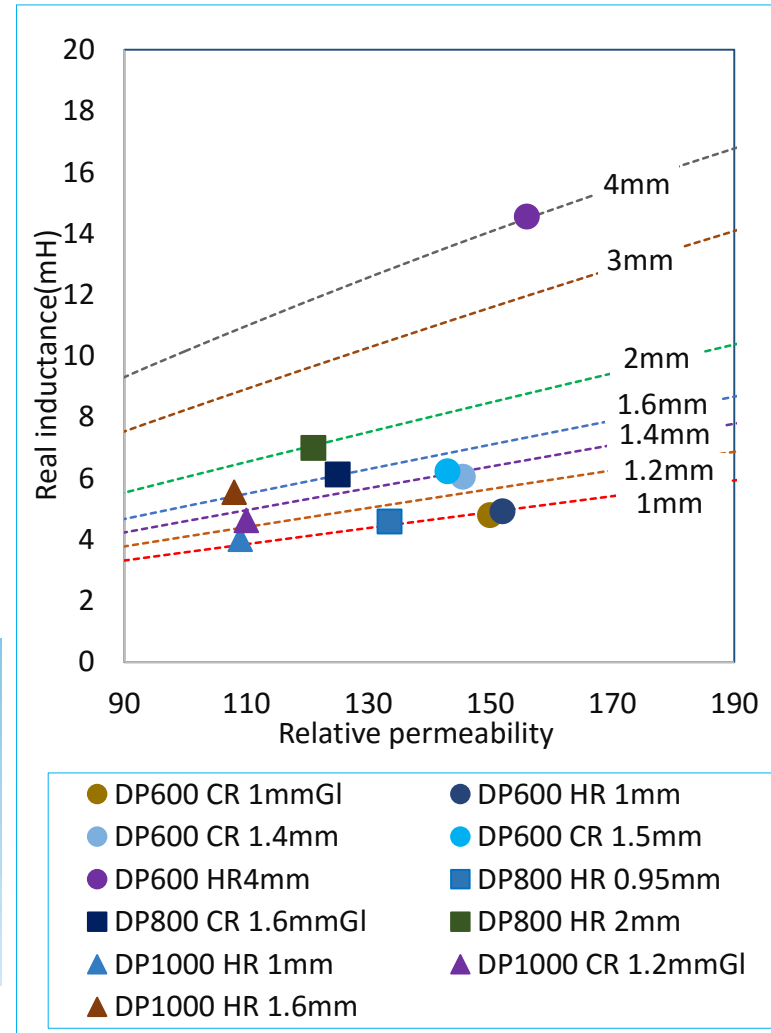

Accuracy of System

- Blind tests have been carried out for six unknown samples of different DP grade and thickness (1 – 2 mm).
- Estimated the tensile strength using the EM sensor and calibration curve.
- The reproducibility and sensitivity of the system in term of sensor design and FE model can be improved.

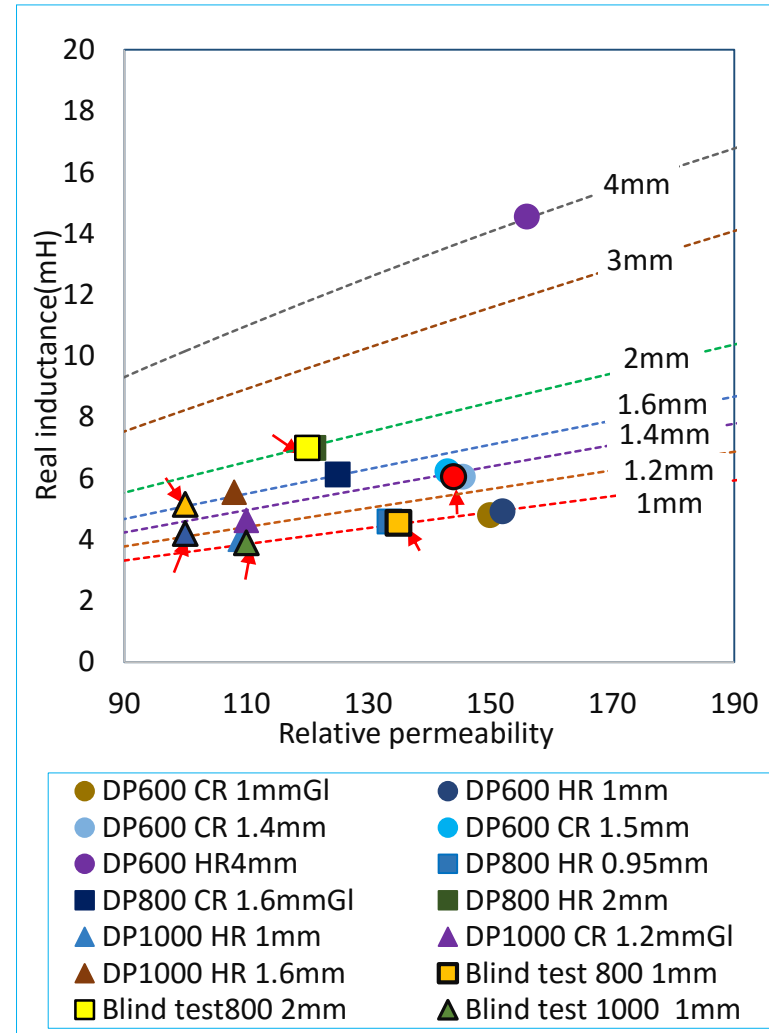

Accuracy of System

- Blind tests have been carried out for six unknown samples of different DP grade and thickness (1 – 2 mm).
- Estimated the tensile strength using the EM sensor and calibration curve.
- The reproducibility and sensitivity of the system in term of sensor design and FE model can be improved.

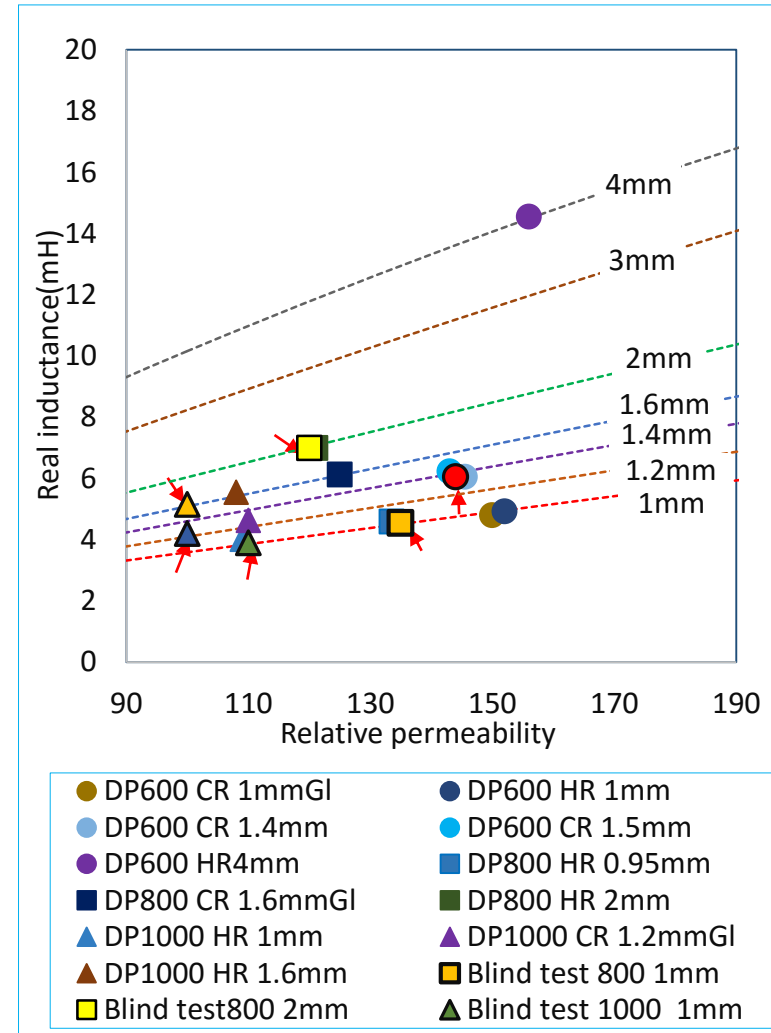
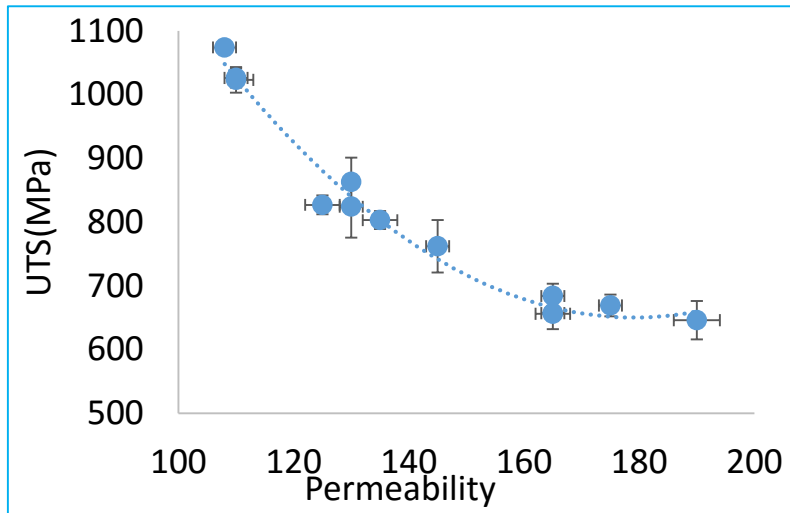

Accuracy of System

- Blind tests have been carried out for six unknown samples of different DP grade and thickness (1 – 2 mm).
- Estimated the tensile strength using the EM sensor and calibration curve.
- The reproducibility and sensitivity of the system in term of sensor design and FE model can be improved.

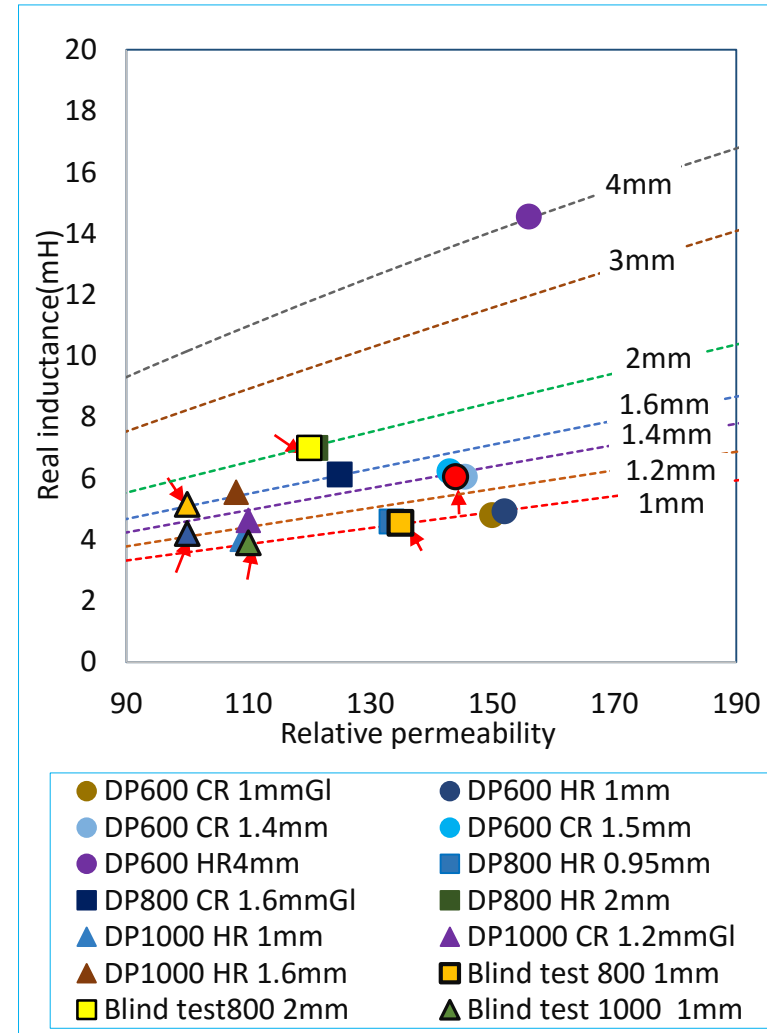
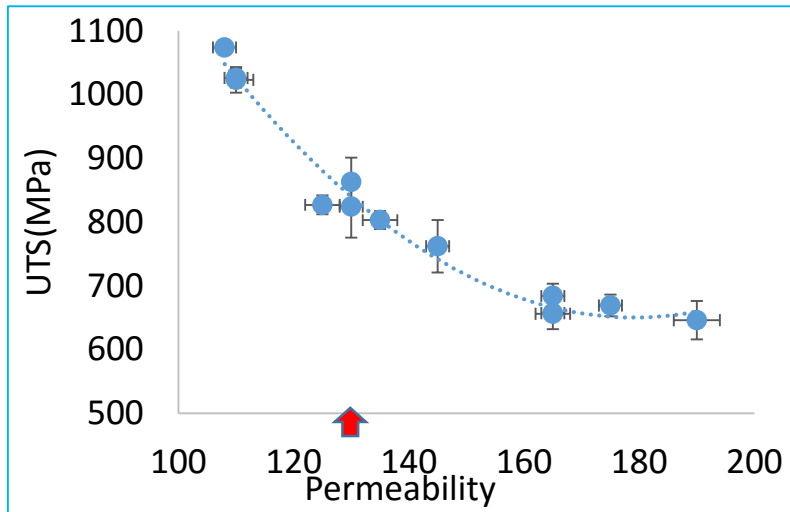

Accuracy of System

- Blind tests have been carried out for six unknown samples of different DP grade and thickness (1 – 2 mm).
- Estimated the tensile strength using the EM sensor and calibration curve.
- The reproducibility and sensitivity of the system in term of sensor design and FE model can be improved.

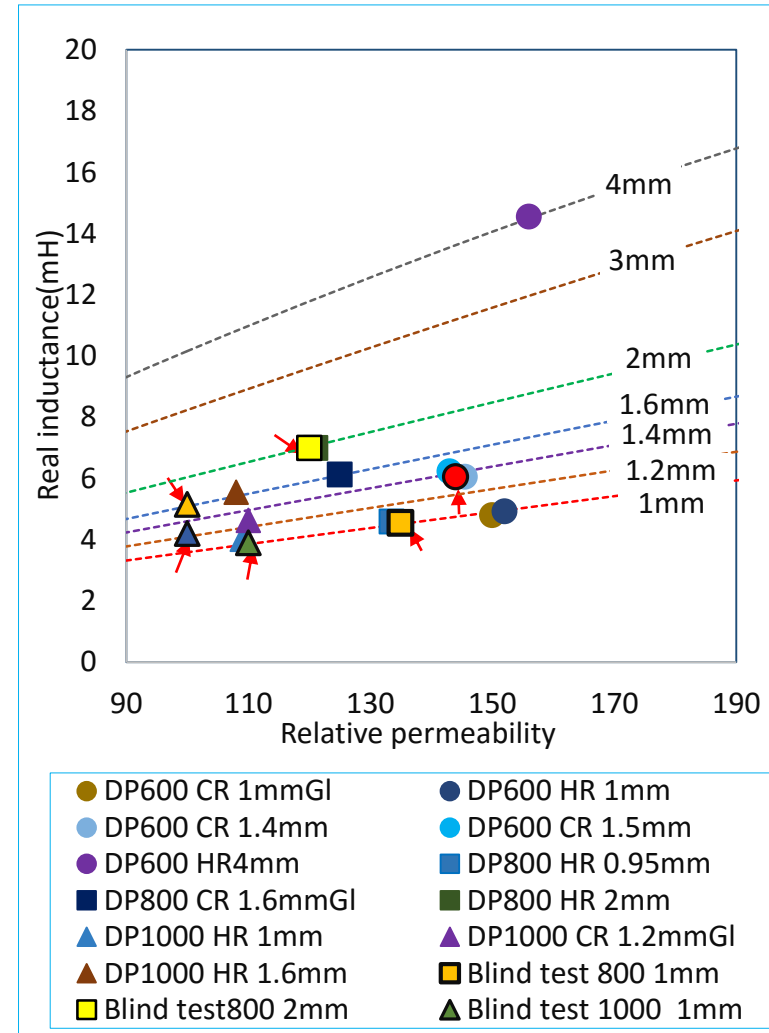
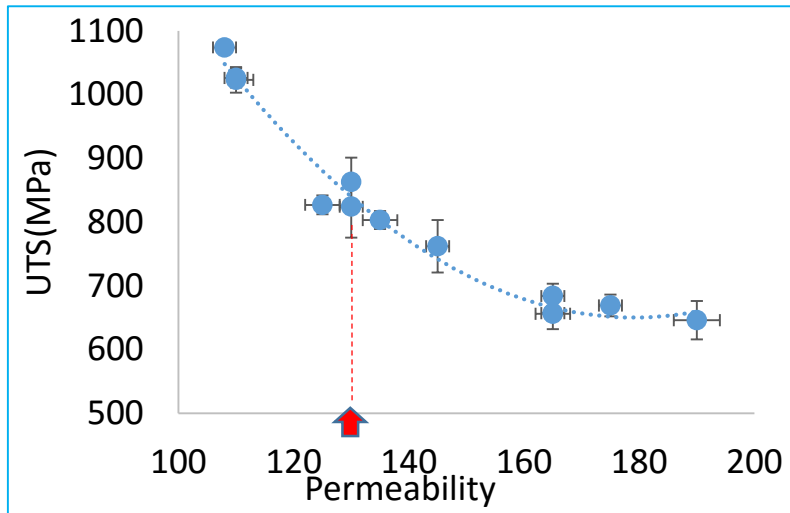

Accuracy of System

- Blind tests have been carried out for six unknown samples of different DP grade and thickness (1 – 2 mm).
- Estimated the tensile strength using the EM sensor and calibration curve.
- The reproducibility and sensitivity of the system in term of sensor design and FE model can be improved.

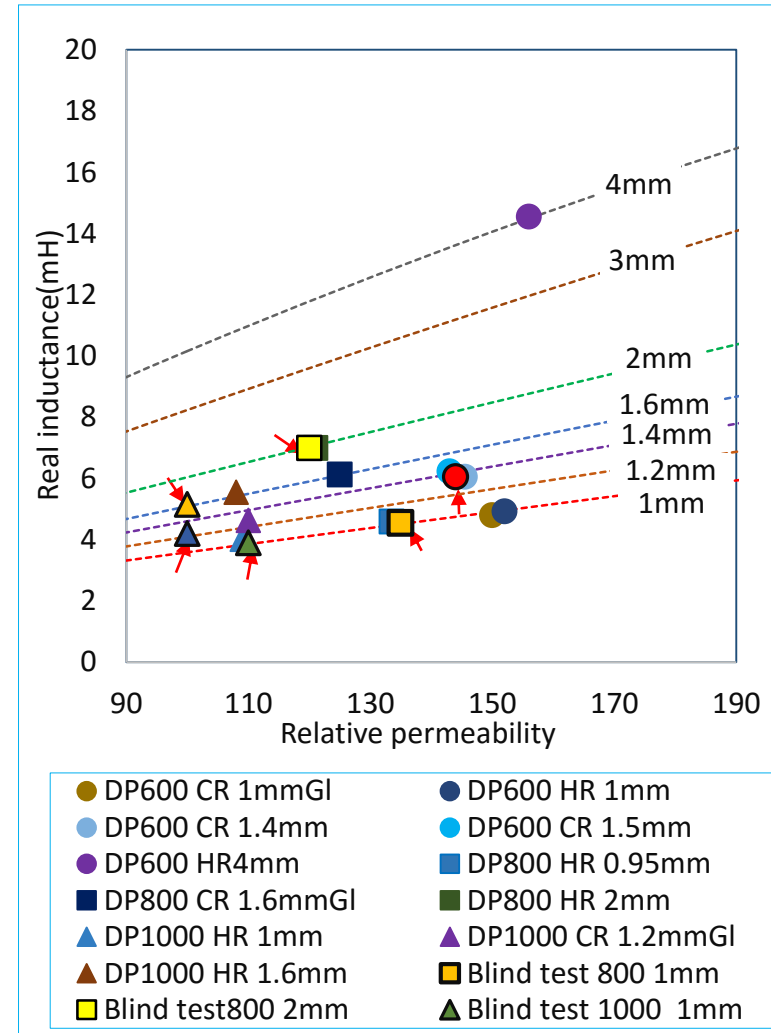
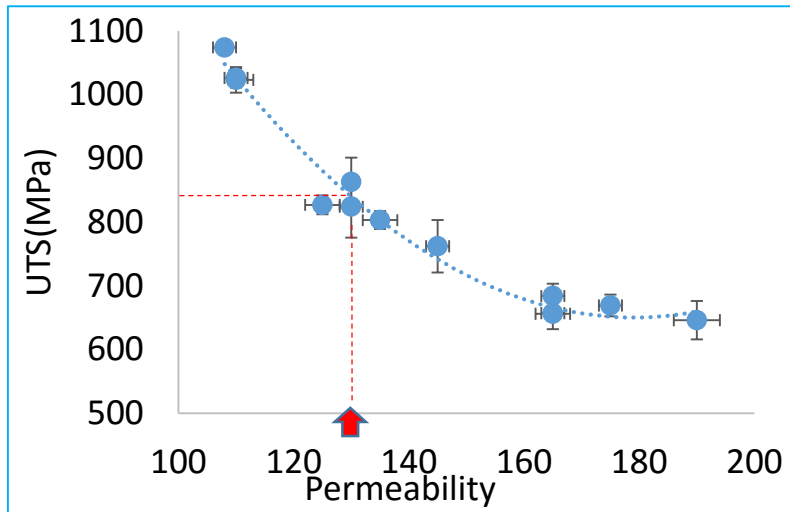

Accuracy of System

- Blind tests have been carried out for six unknown samples of different DP grade and thickness (1 – 2 mm).
- Estimated the tensile strength using the EM sensor and calibration curve.
- The reproducibility and sensitivity of the system in term of sensor design and FE model can be improved.

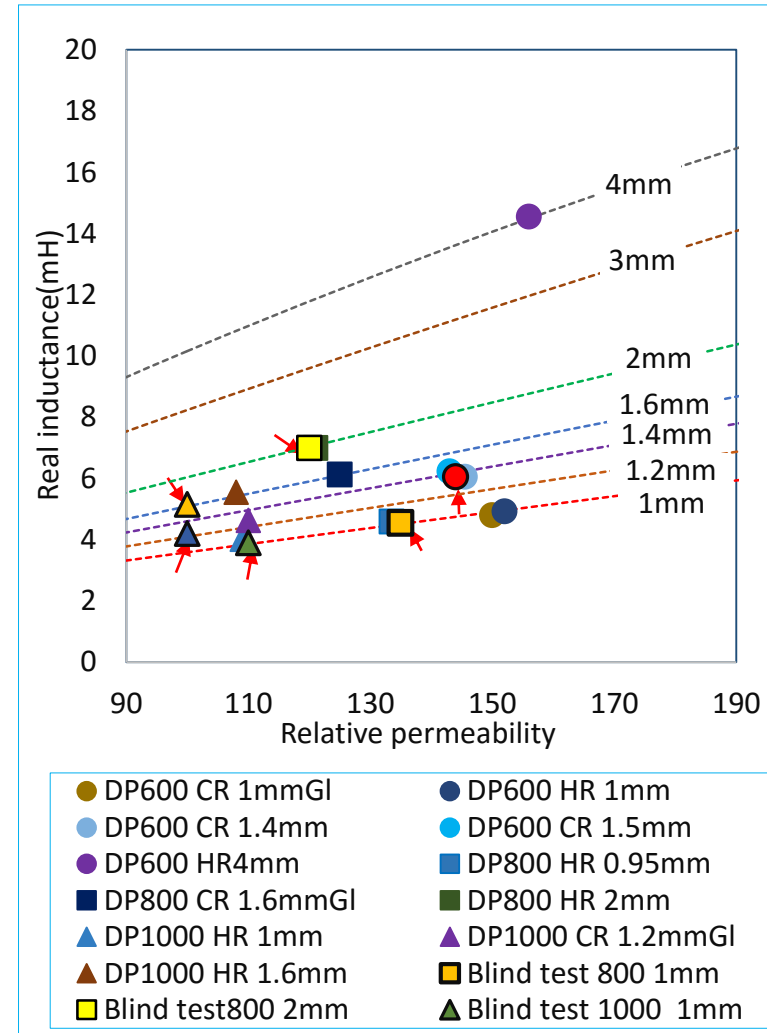
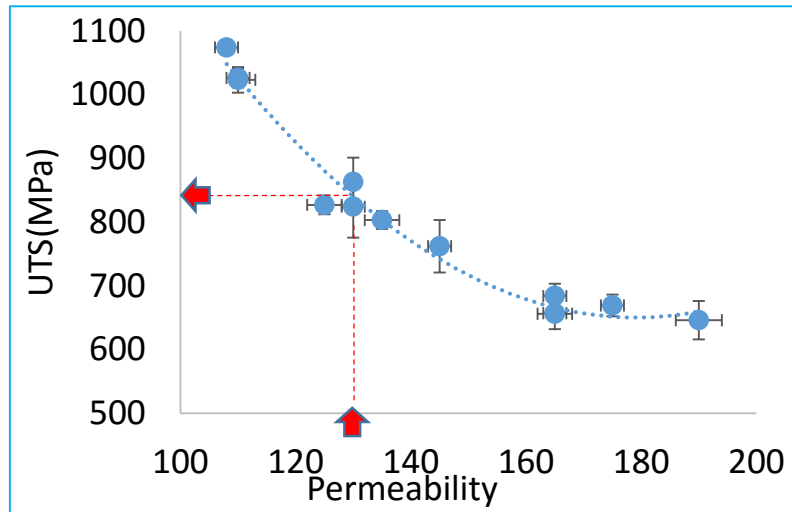

Considerations for development of deployable system

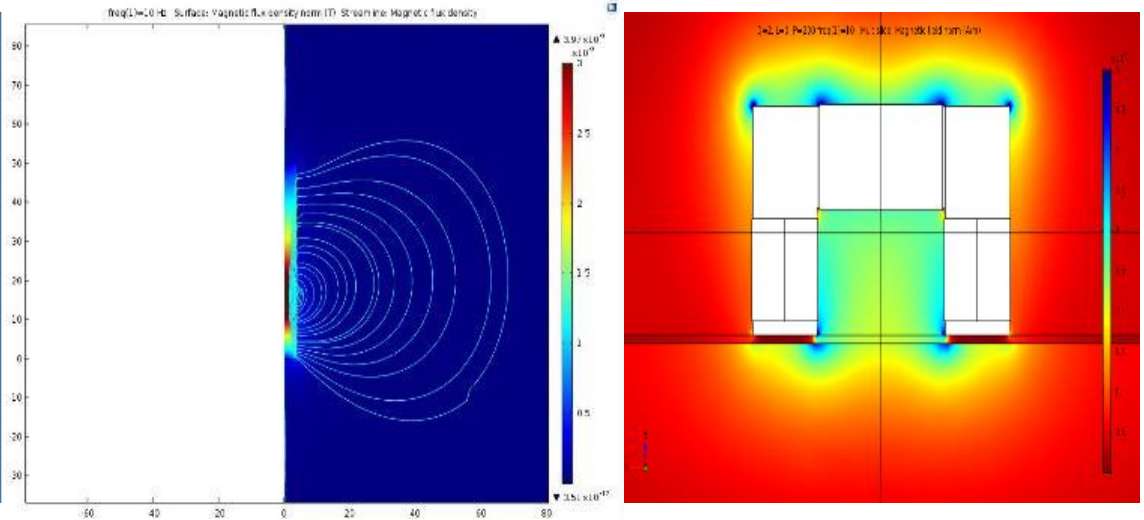
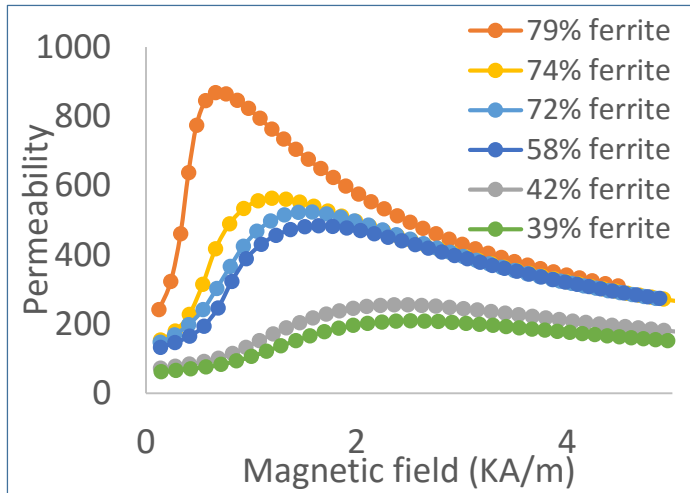

- Consideration is needed to ensure that the applied magnetic field of the deployable sensor used is known as permeability is affected by field and that this needs to be kept constant to allow the developed calibration curve to be used otherwise errors will arise.
- The variation of magnetic field with respect to sample and operation conditions (e.g. lift off) can be determined.

Considerations for development of deployable system

The EM sensor is operated at this field.

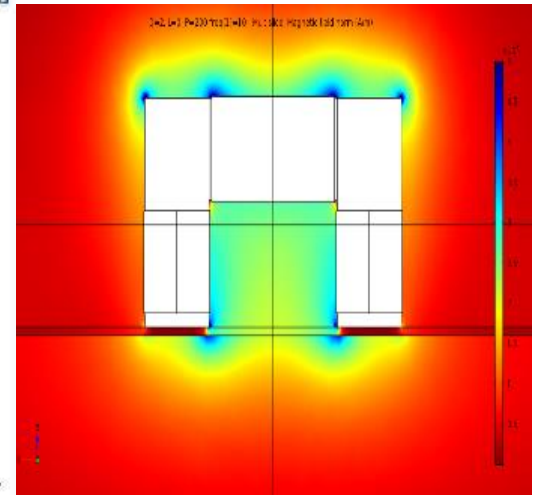
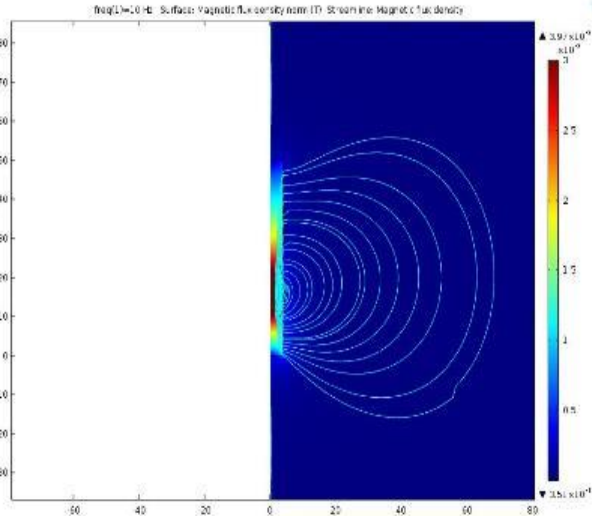
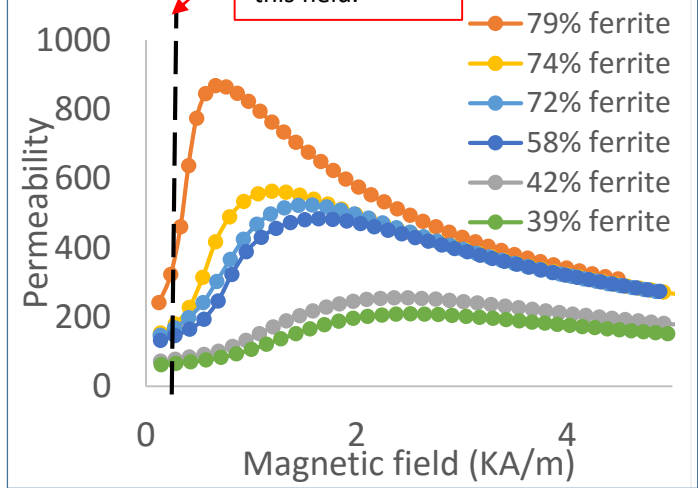

- Consideration is needed to ensure that the applied magnetic field of the deployable sensor used is known as permeability is affected by field and that this needs to be kept constant to allow the developed calibration curve to be used otherwise errors will arise.
- The variation of magnetic field with respect to sample and operation conditions (e.g. lift off) can be determined.

Considerations for development of deployable system

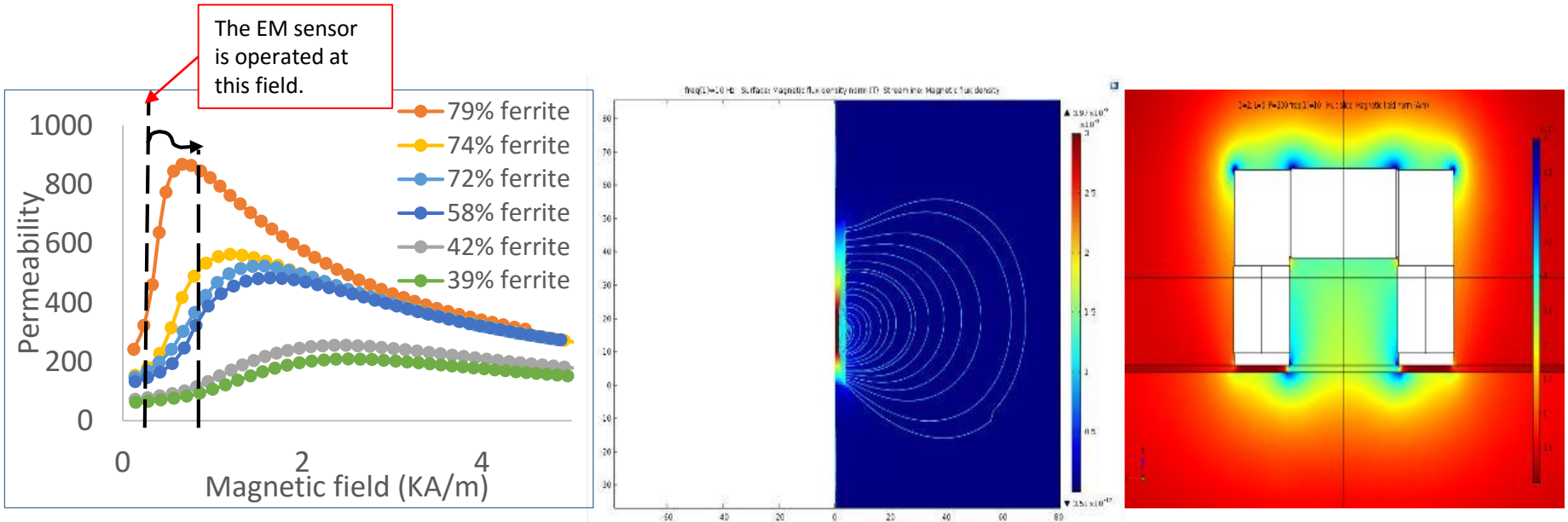

- Consideration is needed to ensure that the applied magnetic field of the deployable sensor used is known as permeability is affected by field and that this needs to be kept constant to allow the developed calibration curve to be used otherwise errors will arise.
- The variation of magnetic field with respect to sample and operation conditions (e.g. lift off) can be determined.

Summary

- The permeability can be determined from the low frequency mutual inductance measured using a U shaped EM sensor for any sheet thickness using a calibration curve to account for the effect of thickness.
- The permeability is affected by ferrite fraction and ferrite grain size for DP steels, both of which affect the tensile strength, therefore a single relationship between permeability and tensile strength results.
- The ferrite fraction in DP steels can be obtained from the permeability if the grain size remains similar.
- The effect of ferrite grain size on permeability and strength for samples with 40% ferrite is less significant and for samples with more than 70% ferrite, is more dominant.
- EM sensor system can be developed for CP steel to estimate tensile strength.

**Thank you for your
attention**

Any questions?